

HANOVER® EDGE 200

Edge Restraint for Interlocking Paving Units



Hanover® Edge 200 is a one piece edge restraint systems designed to work with the interlocking design of the paver system and resist freeze thaw independent movement. Made from UV resistant 100% recycled material, Hanover's edging will provide unit paver system interlock which is essential to a long lasting and stable paver installation. Hanover® Edge 200 has been designed with a strength rib for incredible durability. Curves, radii and straight edges can all be achieved with one piece; simply cut the back and flex to desired radius. By incorporating a lip, Hanover® Edge 200 utilizes the downward pressure of load and the weight of the pavers to tie the edging to the pavement. Use with Hanover's Edging Spikes for quick and simplified installation. With an open base, soil can be backfilled and grass will grow through the voids in the edging and up to the paver edge. Edge 200 is well suited for both commercial and residential applications.

- 100% recycled material
- UV resistant
- Commercial and residential applications
- Quick and easy installation
- Curves, radii and straight edges
- Open base for grass growth
- Lip added for increased stability
- Weight of pavers ties edging to the paver system

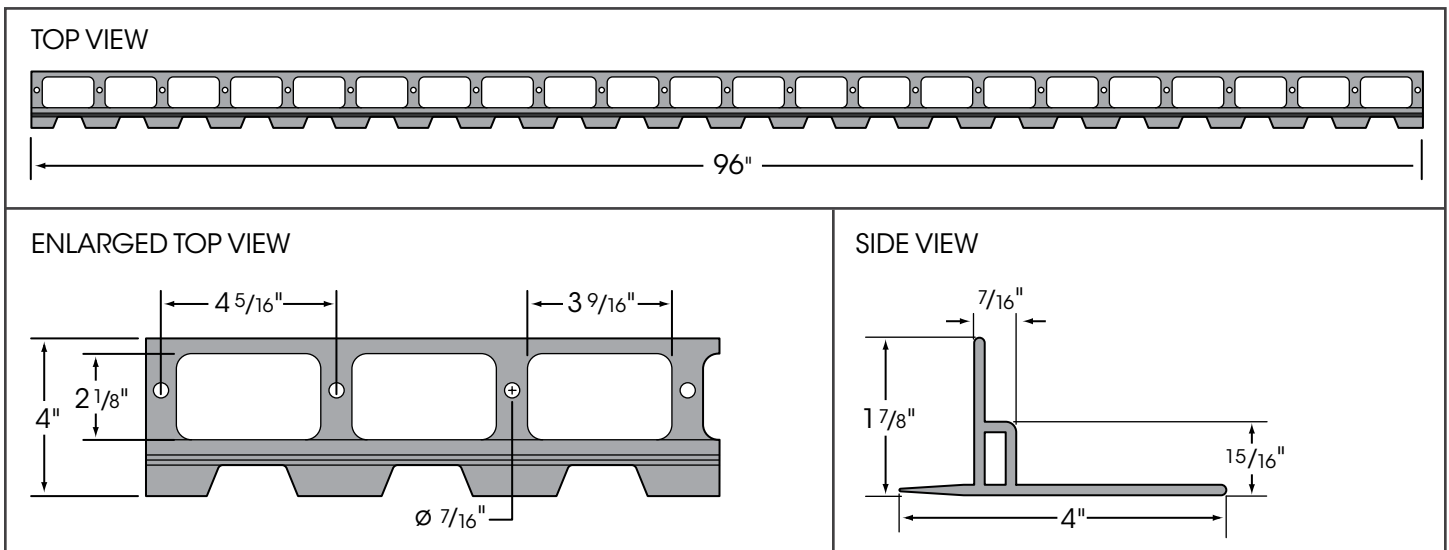

Length: 8' or 96" Height: 1 7/8" Depth: 4"

PACKAGING

- 1 Bundle = 6 pieces = 48 feet = 18 lbs
- 1 Pallet = 330 pieces = 2640 feet = 1228 lbs
- 55 Bundles = 1 pallet

Please Note : Weights shown are approximate.

HANOVER®
Architectural Products
 5000 Hanover Road, Hanover, PA 17331
 717.637.0500 • fax 717.637.7145
www.hanoverpavers.com