

HANOVER® EDGE 100

Edge Restraint for Interlocking Paving Units



Hanover® Edge 100 is a one piece edge restraint system made from UV resistant 100% recycled material. Hanover's edging will provide unit paver system interlock which is essential to a long lasting and stable paver installation. Designed with a strength rib, Hanover® Edge 100 has incredible durability. Curves, radii and straight edges can all be achieved with one piece; simply cut the back and flex to desired radius. Use with Hanover's Edging Spikes for a quick and simplified installation. With an open base, soil can be backfilled and grass will grow through the voids in the edging and up to the paver edge. Hanover® Edge 100 is well suited for both commercial and residential applications.

- 100% recycled material
- UV resistant
- Commercial and residential applications
- Quick and easy installation
- Curves, radii and straight edges
- Open base for grass growth

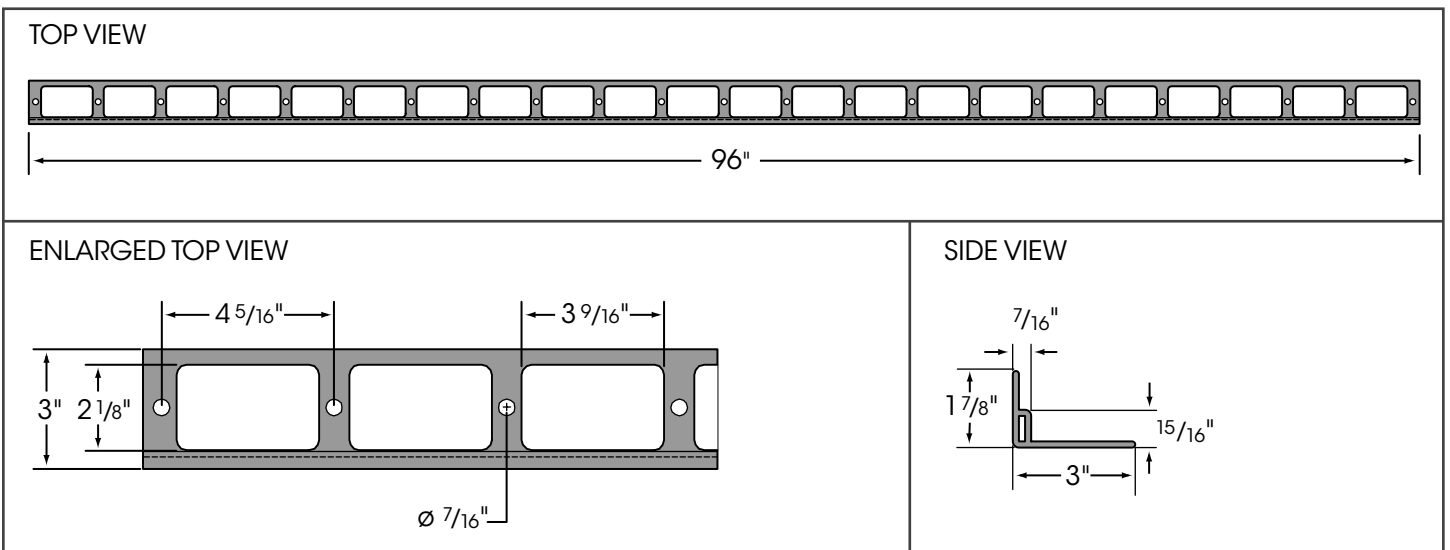

Length: 8' or 96" Height: 1 7/8" Depth: 3"

PACKAGING

- 1 Bundle = 12 pieces = 96 feet = 33 lbs
- 1 Pallet = 660 pieces = 5280 feet = 1958 lbs
- 55 Bundles = 1 pallet

Please Note : Weights shown are approximate.

HANOVER®
Architectural Products
5000 Hanover Road, Hanover, PA 17331
717.637.0500 • fax 717.637.7145
www.hanoverpavers.com